

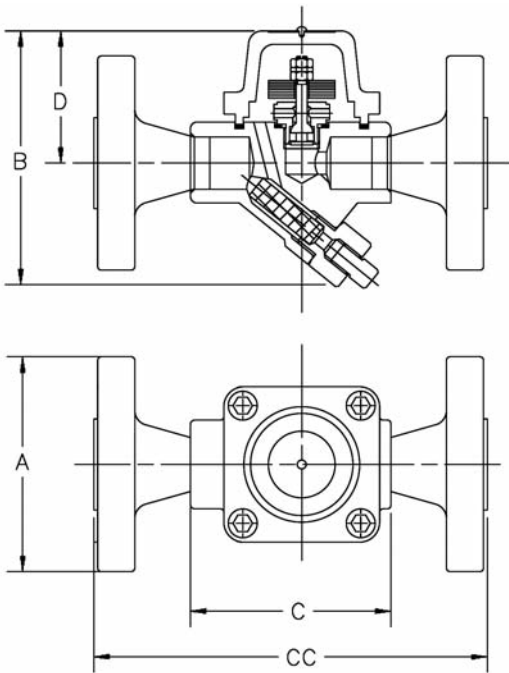

SH-300 Bimetallic Steam Trap

Carbon Steel

For Pressures to 22 bar...Capacities to 2 100 kg/h



Steam Traps

Connections

Screwed BSPT and NPT
Socketweld
Flanged DIN or ANSI (welded)

Materials

Body and cap: ASTM A105
Valve: Chrome Steel - 440C
Seat: Stainless steel - 303
Bimetallic elements: Nickel plated

Specification

Bimetallic steam trap type SH-300 in carbon steel. Maximum allowable back pressure 99% of inlet pressure.

How to Order

Specify:

- Model number
- Size and type of pipe connection.

Description

The SH-300 steam trap operates on the temperature principle using two layers of bimetallic elements that have different expansion coefficients. The stem connected to these elements moves a valve into either an open or closed position.

During start-up, the trap is cold so the elements are flat and the valve is wide open. This results in air and condensate being easily removed from the system.

In standard operation, the position of the valve depends on two parameters: first, the pressure, which will cause the valve to open; and second, the temperature, which will cause the elements to convex and the valve to close.

When no condensate is present and set temperature is reached, the force of the elements is then high enough to completely close the valve.

The SH-300 steam trap can adjust itself to changing conditions, because if the pressure rises, the higher pressure works on the valve. At the same time, the higher temperature will work on the elements.

Maximum Operating Conditions

Maximum allowable pressure (vessel design)†: 32 bar @ 350°C
Maximum operating pressure: 22 bar
Maximum back pressure: 99% of inlet pressure

Table ST-154-2. Model SH-300 Capacity

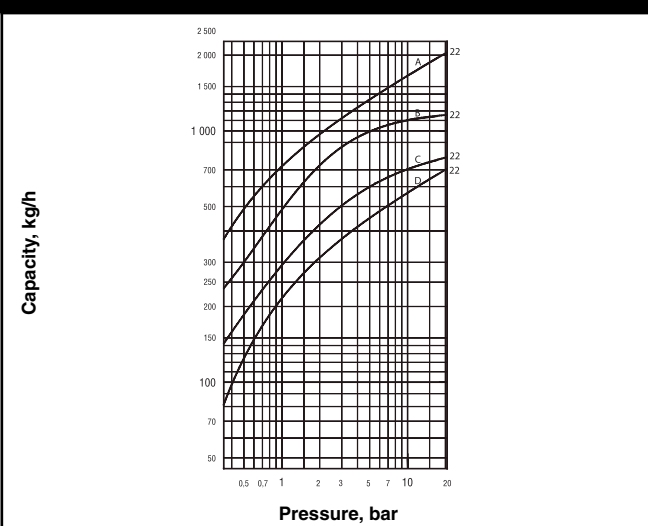

A = Cold Water
B = 40°C Below Saturation
C = 20°C Below Saturation
D = 10°C Below Saturation

Table ST-154-1. Model SH-300 Trap (dimensions in mm)

Model No.	SH-300
Pipe Connections	15 - 20 - 25
"B" Height (screwed & SW)	115
"A" Height (flanged PN40*)	115
"C" Face-to-Face (screwed & SW)	90 - 90 - N/A
"CC" Face-to-Face (flanged PN40*)	150 - 150 - 160
"D" \varnothing to Top	60
Weight in kg (screwed & SW)	1,9
Weight in kg (flanged PN40*)	4,3 - 4,5 - 4,7

* Other flange sizes, ratings and face-to-face dimensions are available on request. All sizes comply with the article 3.3 of the PED (97/23/EC).

† May be derated depending on flange rating and type.

All dimensions and weights are approximate. Use certified print for exact dimensions. Design and materials are subject to change without notice.